

**Features:**

- ◆High intensity
- ◆Normal 5mm diameter package
- ◆General purpose leads
- ◆Reliable and rugged

**Package Dimensions:**

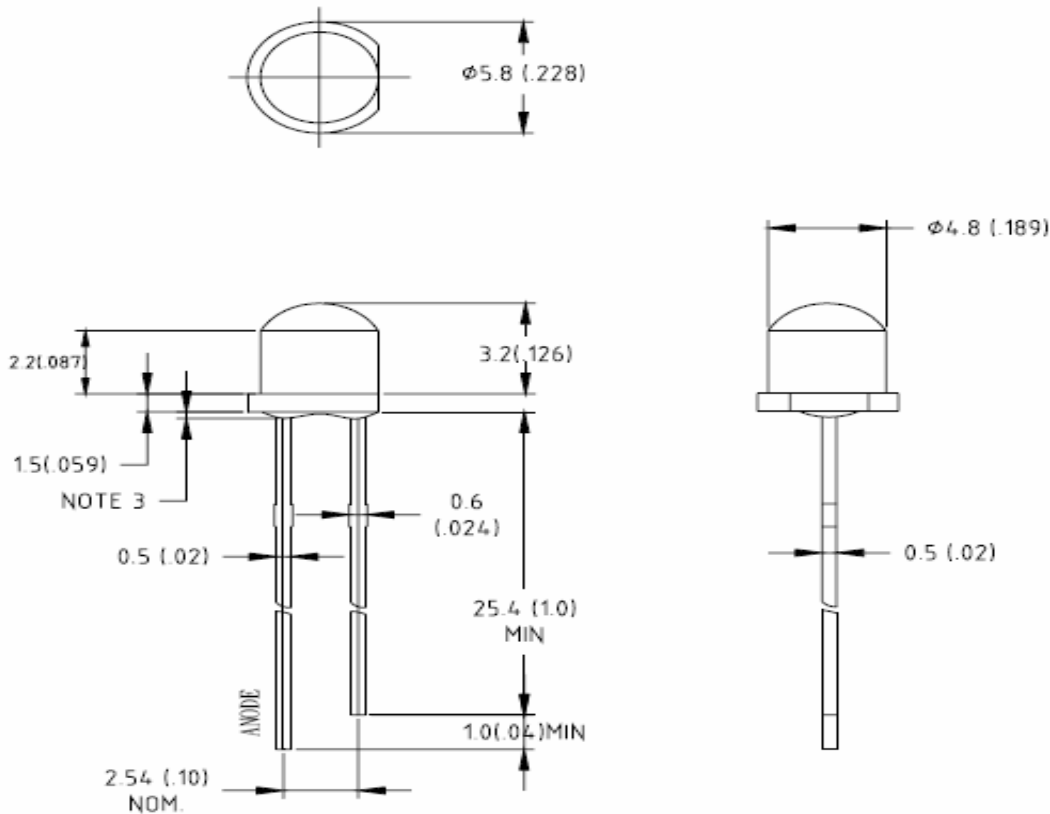

| Part NO.   | Chip Material | Lens Color  | Source Color |
|------------|---------------|-------------|--------------|
| DDY-GK335W | InGaN         | Water Clear | White        |

**Notes:**

1. All dimensions are in millimeters (inches).
2. Tolerance is  $\pm 0.25\text{mm}$  (.010") unless otherwise noted.
3. Protruded resin under flange is 1.0mm (.04") max
4. Lead spacing is measured where the leads emerge from the package.
5. Specifications are subject to change without notice.
6. This data-sheet only valid for six months.

**Absolute Maximum Ratings at Ta=25°C**

| Parameter  | MAX.                | Unit  |
|--|---------------------|-------|
| Power Dissipation  | 70                  | mW    |
| Peak Forward Current<br>(1/10 Duty Cycle, 0.1ms Pulse Width) | 100                 | mA    |
| Continuous Forward Current                                   | 20                  | mA    |
| Derating Linear From 50°C                                    | 0.4                 | mA/°C |
| Reverse Voltage  | 5                   | V     |
| Operating Temperature Range                                  | -40°C to +80°C      |       |
| Storage Temperature Range                                    | -40°C to +80°C      |       |
| Lead Soldering Temperature<br>[4mm(.157" ) From Body]        | 260°C for 5 Seconds |       |

### Electrical Optical Characteristics at Ta=25°C

| Parameter           | Symbol             | Min.                  | Typ. | Max. | Unit | Test Condition                |
|---------------------|--------------------|-----------------------|------|------|------|-------------------------------|
| Luminous Intensity  | I <sub>v</sub>     | 1800                  | 2000 | 2300 | Mcd  | I <sub>f</sub> =20mA (Note 1) |
| Viewing Angle       | 2 θ <sub>1/2</sub> | 110                   | 120  | 150  | Deg  | (Note 2)                      |
| Dominant Wavelength | X, Y               | X=0.30 Y=0.31 (±0.05) |      |      |      | I <sub>f</sub> =20mA (Note 3) |
| Forward Voltage     | V <sub>f</sub>     | 3.0                   | 3.1  | 3.2  | V    | I <sub>f</sub> =20mA          |
| Reverse Current     | I <sub>R</sub>     | ---                   | ---  | 10   | uA   | V <sub>R</sub> =5V            |

#### Notes:

1. Luminous intensity is measured with a light sensor and filter combination that approximates the CIE eye-response curve.
2. θ<sub>1/2</sub> is the off-axis angle at which the luminous intensity is half the axial luminous intensity.
3. The dominant wavelength (λ<sub>d</sub>) is derived from the CIE chromaticity diagram and represents the single wavelength which defines the color of the device.

**Typical Electrical / Optical Characteristics Curves (25°C Ambient Temperature Unless Otherwise Noted)**

Forward Current Vs Forward Voltage

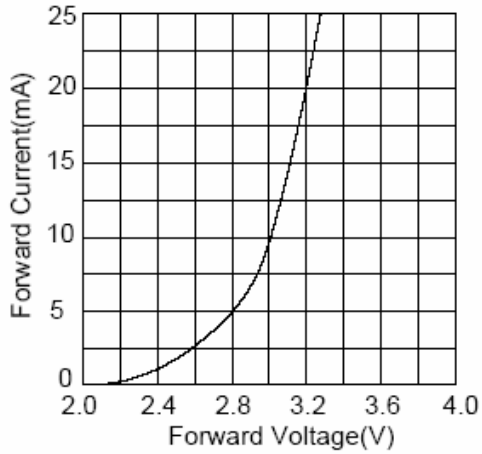

Luminous Intensity Vs. Forward Current

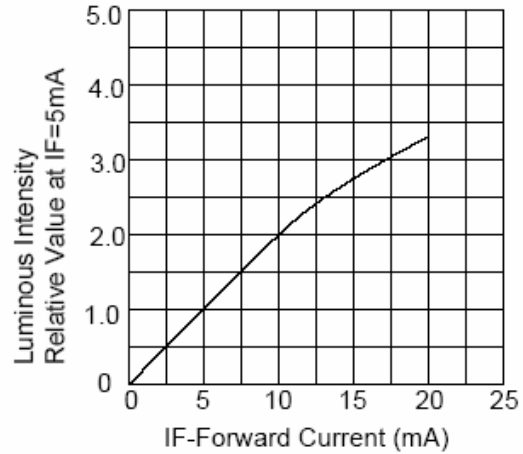

Relative Luminous Intensity VS Wavelength

